



Knockers «FKL in»

Variable impact force and interval.

Properties

- Single or interval impact mode
- Variable impact force and interval
- Lubrication-free
- Flexible range of application
- Can be used up to 120°C, HT version up to 150°C and LT version down to -40°C on request
- Also available with ATEX certification

Field of application

Broad field of application. Knocking off adhering material from container walls such as silos, chutes, filter outlets, reactors and pipelines.

Construction

A piston is forced against a spring by compressed air. With rapid venting, the piston closes against a baffle plate. Knocker housing made of aluminium, baffle plate made of impact-resistant special plastic.

Interval impact mode

The impact depends on the interval time which is set by means of a throttle valve.

The force is adjusted by the three control bores 1 - 3.

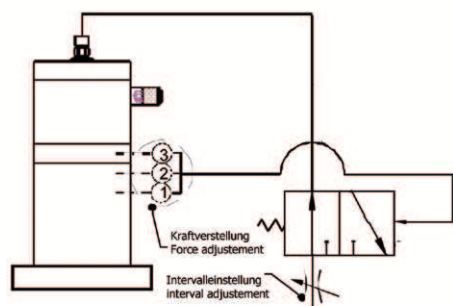

Single impact mode

The impact is triggered immediately after the 3/2-way valve switches. Several knockers can be switched in parallel.

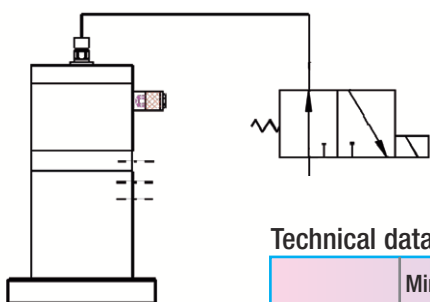

Dimensions

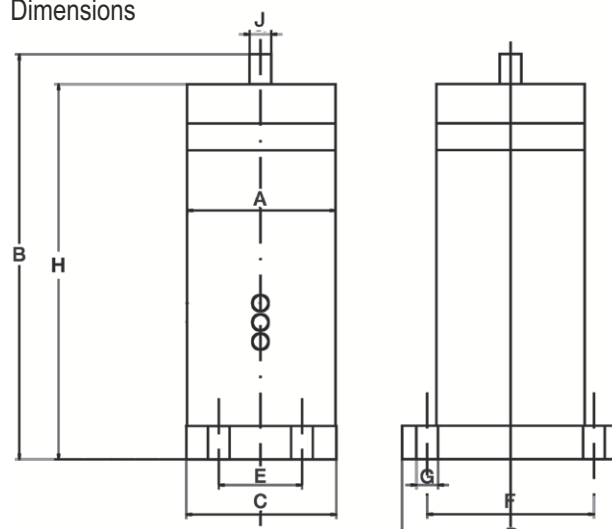

Dimensions in mm

Model	A	B	C	D	E	F	G	M	N
FKL- 25 in	ø 52	170	53	88	-	70	9	153	13
FKL- 50 in	ø 64	194	66	115	-	90	13	177	13
FKL-100 in	ø 89	242	90	130	50	100	13	224	13
FKL-150 in	ø 118	330	-	ø 140	-	ø 115	13	310	13
FKL 200 in	ø 147	337	-	ø 180	-	ø 152	17	319	13

Technical data

Model	Min. op. Pressure (bar)			Work/Impact Nm	Impulse/Impact Ns	Stroke vpm	Air consumption l/stroke	For wall thicknesses up to mm	Weight kg
	①	②	③						
FKL-25 in	3.0	4.5	6.5	1 - 7	0.1 - 1.4	max. 10	0.07 - 0.2	2	1.03
FKL-50 in	3.0	4.5	6.5	5 - 21	1.2 - 4.7	max. 10	0.1 - 0.3	3	1.85
FKL-100 in	4.0	5.0	6.5	10 - 70	2.1 - 14.7	max. 10	0.5 - 1.1	5	4.5
FKL-150 in	5.3	6.7	8.0	50 - 196	10.4 - 40.6	max. 10	1.2 - 2.0	8	9.5
FKL-200 in	5.3	6.7	8.0	100 - 280	28.8 - 80.5	max. 10	2.2 - 3.3	12	14.8