

ON-LINE MANUAL Operation

6. Installation and operation of the vibrator

6.1 Mounting

Before mounting the vibrator make sure the location has been carefully selected to insure the best working results (refer to Chapter 3).

The mounting area must be clean and even. Please note that an uneven mounting area may cause the vibrator to malfunction due to torsion in the vibrator's body.

The vibrator should be placed, whenever possible, so that the rotation of the ball, roller or turbine supports the direction of material flow.

It is easy to verify the correct placement with the help of the air inlet as shown in figure 6.1.

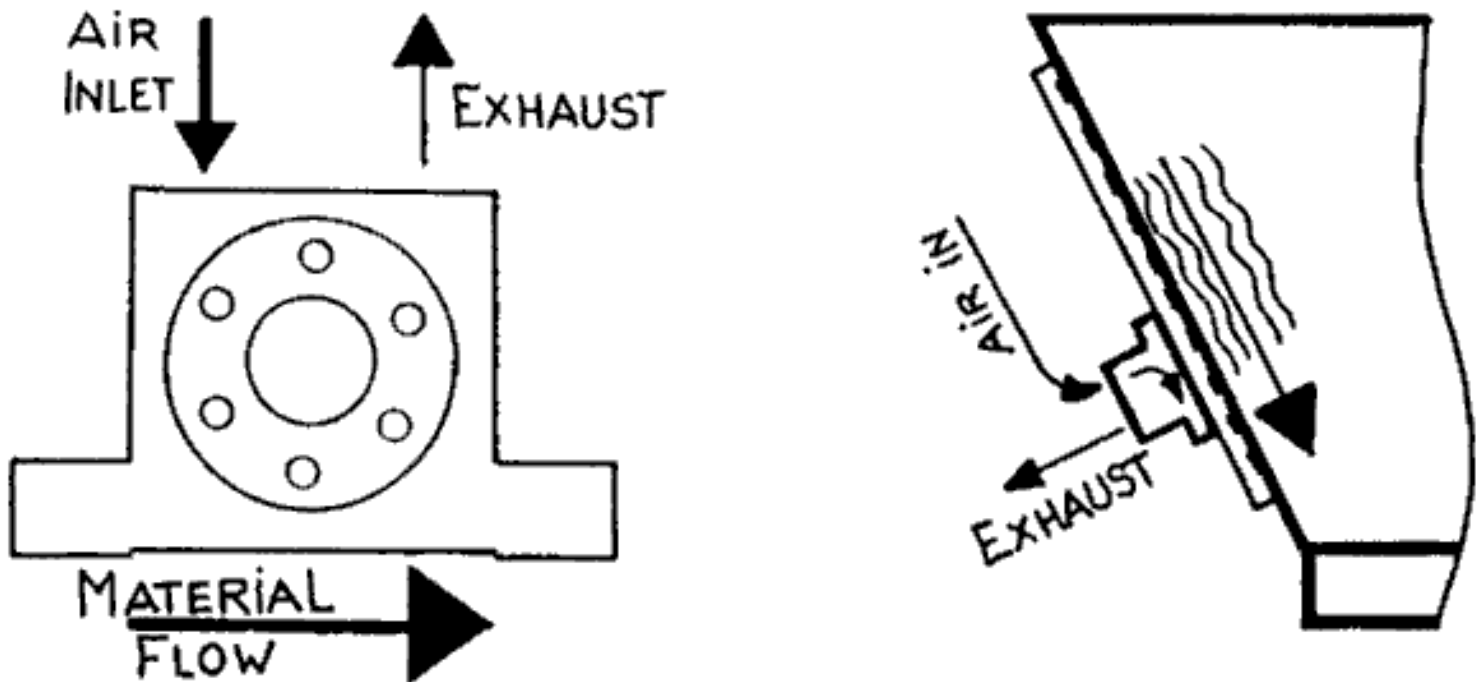

Support of flow and correct placement on a bin

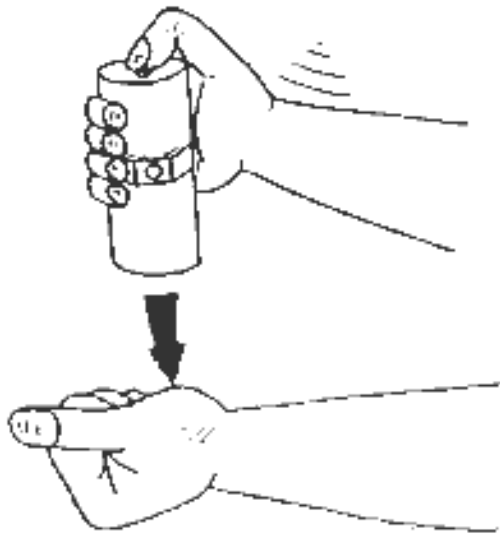

Check free movement of the piston

Before mounting the Piston Vibrator FP-series, check to make sure that the piston is moving freely. Hit the vibrator against the ball of the thumb. You will hear a metallic "clack" of the piston when knocking the end cap. If the piston is not moving freely, add some drops of petroleum (kerosene) into the air inlet. It will loosen the clog of the piston which is probably caused by the congealed oil we use in manufacturing.

6.1.1. Screws and nuts

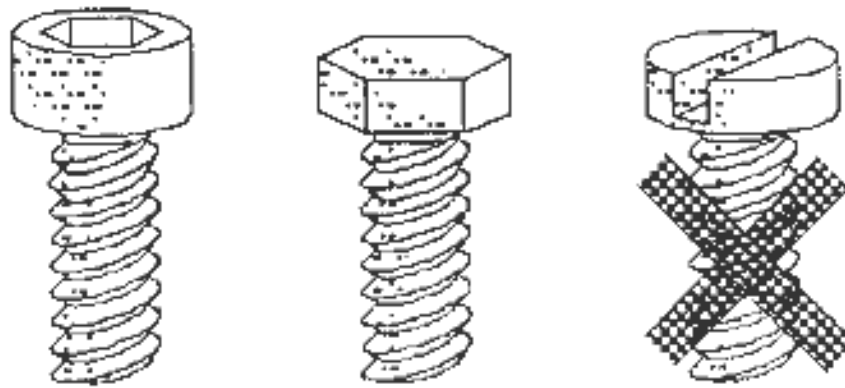

Allen Screws / Hexagon Screw / Slotted Screw

The following screw sizes have to be used:

Model	8/10	13/16	20/25	30/36	40/48	60/70
K-series	M6	M8	M8	M10	----	----
GT-series	M6	M8	M8	M10	M16	M16
Model	50	65	80	100	120	
R-series	M6	M8	M8	M10	M16	

T-series	M6	M8	M10	M12	----	
Model	2	3	4	5	6	7
DAR-series	M6	M8	M10	M12	M16	M16
Model	12	18	25	35		
FP-series	M8	M10	M12	M12		

Allen Screws or Hexagon Screws with a minimum quality of 8.8 are recommended. Similarly, the nuts should conform to 8.8 quality.

Slotted Screws or other types of screws with less tensile strength should be avoided.

The screws should be long enough so that at least one full thread is out of the nut.

If a threaded hole in the object is used for mounting, the screw should be torn in at least 1.5 times the screw diameter.

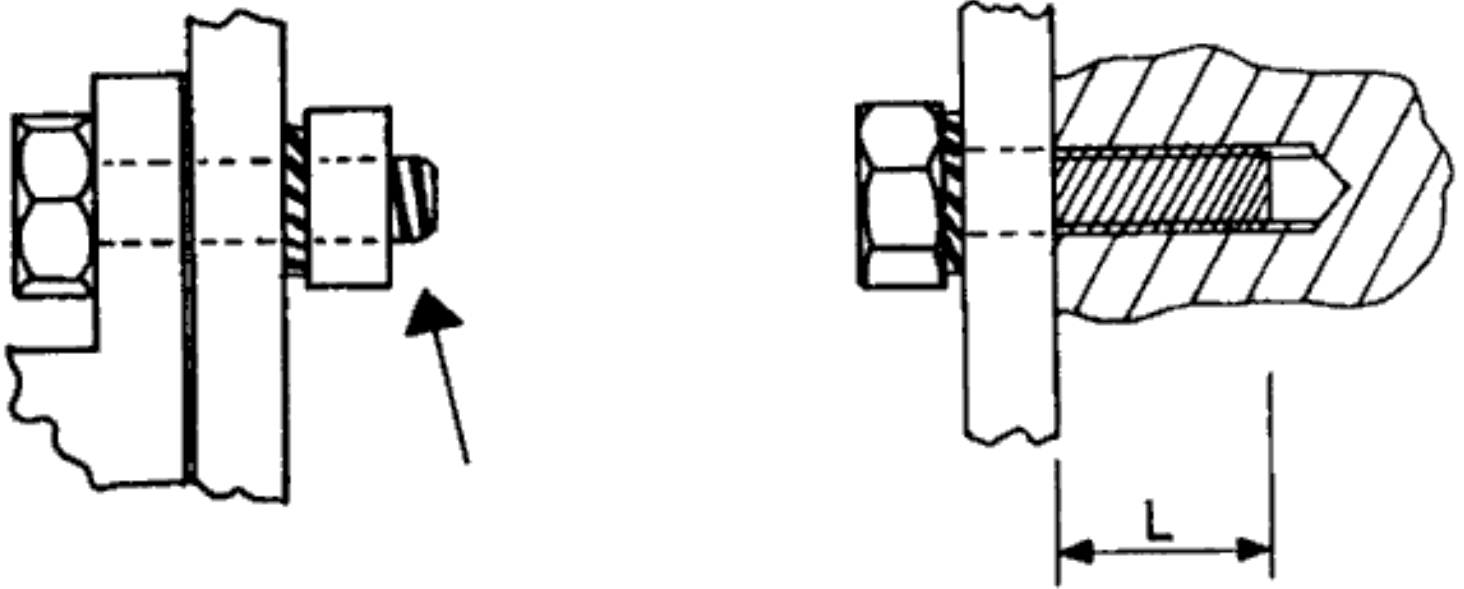

Lengths of the screw in the thread

For FP-series the length of the screw in the vibrator thread should be as follows:

FP-Type	12	18	25	35
Minimum (mm)	10	10	12	12
Maximum (mm)	13	13	15	15

CAUTION: Always use a Tooth Lock Washer or a Spring Lock Washer.

The use of an adhesive sealant (LOCTITE 270 for instance) is suggested. Please follow the manufacturer's instructions.

Never use an ordinary Flat Washer or a Curved Washer because these washers do not stop movement, and loosening of the screw during vibration may occur.

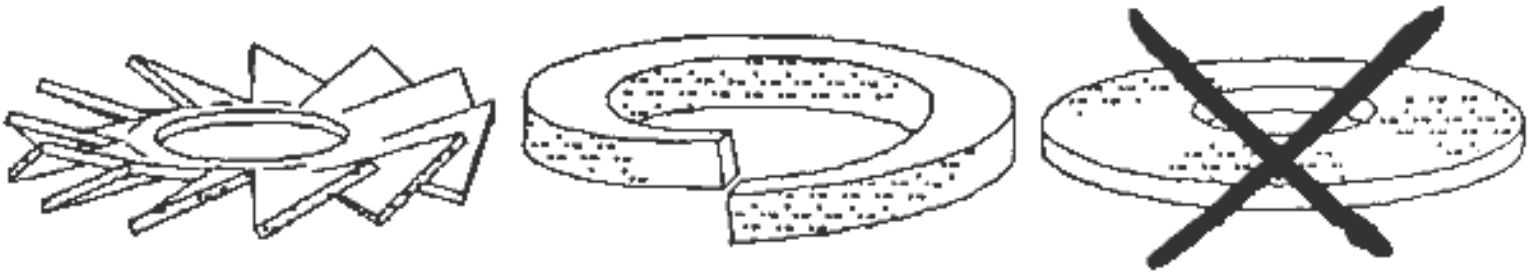

Tooth Lock Washer / Spring Lock Washer / Curved Washer

The washer should be placed between mounting plate and nut, and between mounting plate and screw for FP-vibrators.

The tightening torque must not exceed the following values :

Thread	Minimum	Maximum
M6	6 N	10 N
M8	15 N	21 N
M10	30 N	42 N
M12	50 N	72 N
M16	150 N	174 N

Fig. 6.7. : Minimum / maximum torque

NOTE: FP-series : The socket with the mounting thread is the end cap with the smaller diameter. The thread in the other end cap (air exhaust port) is not metric!

The vibrator is to be placed, whenever possible, so that the rotation of the ball, roller or turbine supports the direction of material flow.

It is easy to verify the correct placement with the help of the air inlet as shown in figure 6.8.

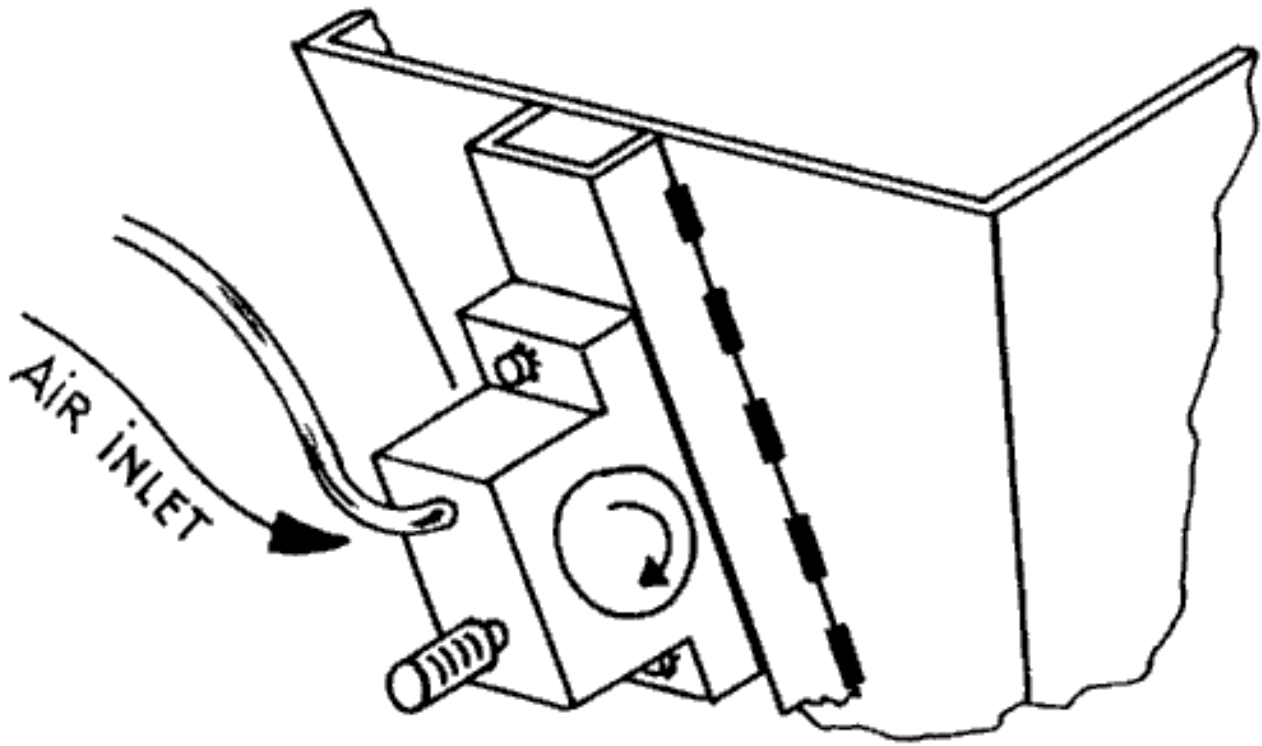

Support of flow and correct placement on a bin

CAUTION: Make sure the vibrator is securely fixed! We strongly recommend that you retighten the screws after a few minutes of operation. A loose vibrator may fall down and harm people or machinery.

6.1.2. Air connection

The air pressure tube should be wide enough to allow a good air flow. The main air line should be dimensioned according to paragraph 2.4.. The connection from the main line to the vibrator is made with a short flexible tube. Make sure the inner span of this flexible connecting tube conforms to figure 6.9.

Profile Type	50	65	80	100	120	180
Inner Span (mm)	8	8	12	16	16	20

Fig. 6.9. : Minimum requirements of inner span of connecting tube

Make sure the air pressure tube at the air inlet port is flexible and freely movable so that vibration does not harm the tube at the transition piece. The tube is to be securely fixed at the object side, so that the tube may not come in resonance. You can let the tube hang from a structure point directly to the inlet port, but make sure that it does not create a safety hazard.

Make sure that the tube can never be buckled.

NOTE: The pipe thread is BSP type (British Standard Pipe) but will accept US NPT (National Pipe Thread) that is conical and has one extra turn per inch. Tighten very closely using Teflon-tape

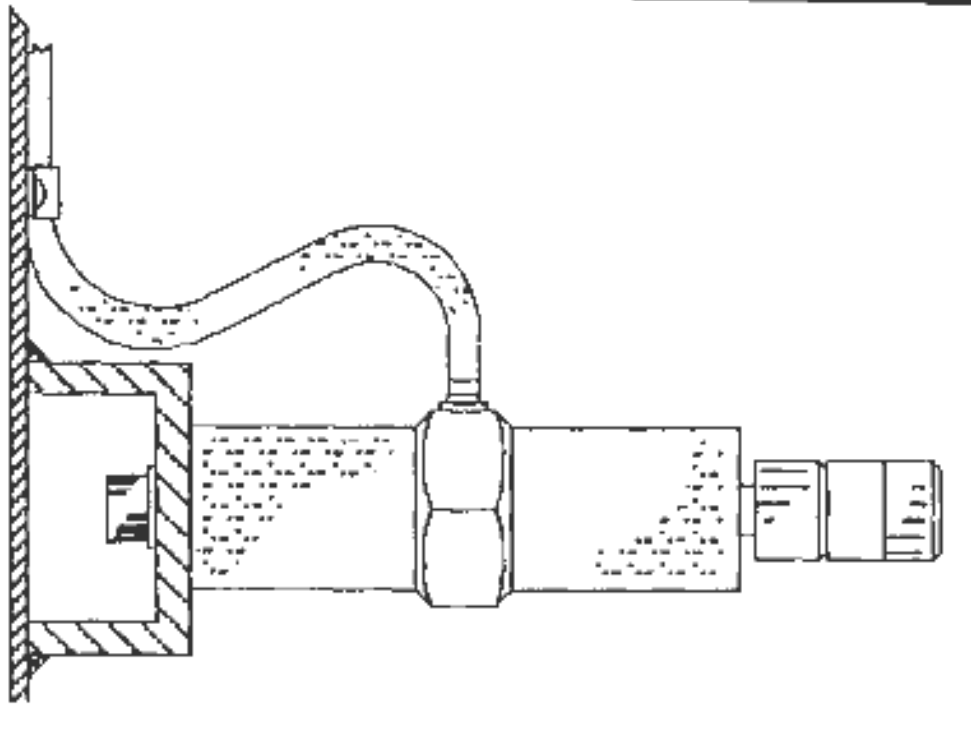

Fixation of the air pressure tube

The filter, regulator and lubricator unit should be placed as close as possible to the vibrator (less than 2 m).

If an electromagnetic valve is connected into the air line for intermittent operation of the vibrator, the distance between vibrator and valve should be less than 50 cm. This will guarantee a proper and immediate start and stop.

Only one lubricator unit needs to be used for a maximum of three vibrators. The lines from the junction to every vibrator should be of the same length to ensure that all vibrators are supplied with same pressure and flow through.

Again, when using electromagnetic valves, place each one within 50 cm of every vibrator so it is guaranteed that all vibrators will start and stop at the same time.

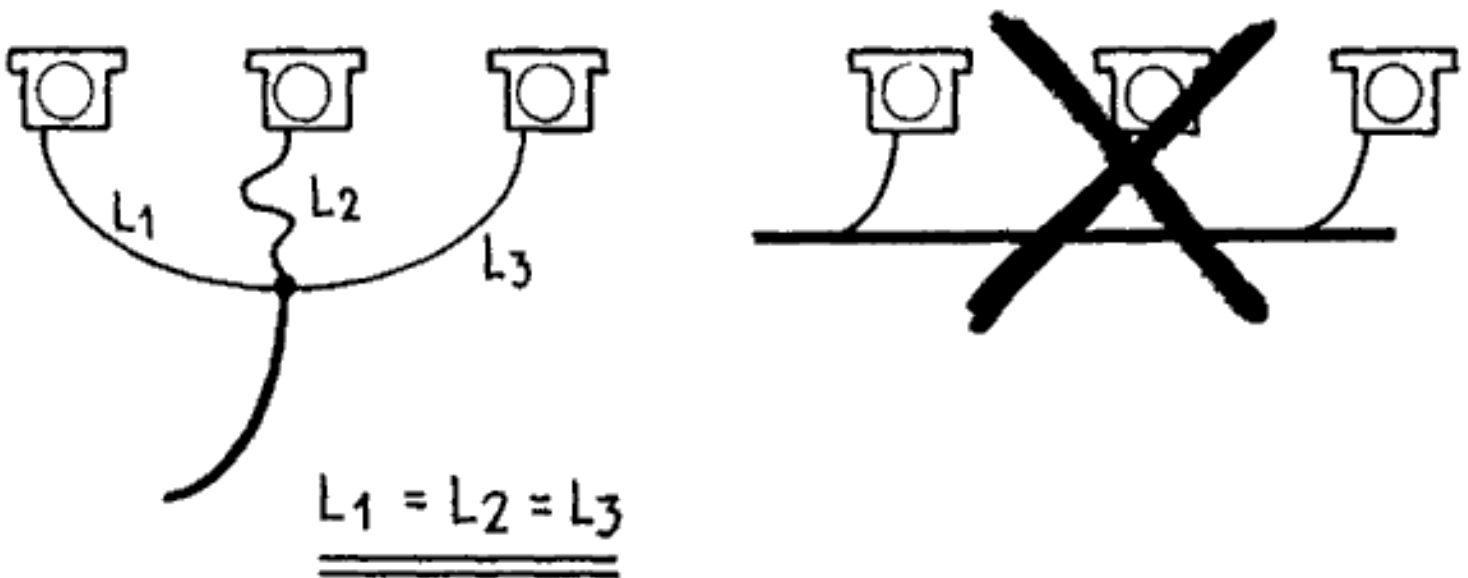

Connection of three vibrators to one lubricator unit

If a lubricator is used, the oil must be ISO VG5 as explained in paragraph 2.2.

Please note that suppliers of servicing units (filter-regulator-lubricator) sell their own oil for lubrication. Please verify it conforms to ISO VG5!

We recommend that you add a few drops of kerosene into the vibrator's air inlet before mounting the air tube. Kerosene will dispel the corrosion protective additive inside new vibrators during the first few seconds of operation.

6.1.3. Silencer

All vibrators except the R-series may be equipped with silencers or an exhaust hose. The use of the following silencers is recommended.

Vibrator Types/Models	Silencer	Size	Order-No.
GT-8 /-10, R-50, FP-12 / -18	Filter Type	1/8"	44025
K-8 to 25, GT-13 to 25, T-50 to 65, R-65 / -80	Filter Type	1/4"	44026
K-30 / -36, GT-30 to 48, T-80 to 100, R-100 / -120	Filter Type	3/8"	44027
DAR-2	Sintered	1/8"	39371
DAR-3 / -4	Sintered	1/4"	39372
DAR-5 / -6 / -7	Sintered	3/8"	39373
FP-25 / 35	Free Flow	1/4"	44029

Fig. 6.12. : Silencer cross reference

Silencers may clog due to dirt in air; hence, the use of air line filters is strongly recommended, but clogged silencers (filter types and sintered types) may be washed out with petroleum (kerosene). FF-types (Free-Flow 1/4") can be unscrewed, and both parts can be blown through with air pressure.

Instead of using silencers the exhaust air may be blown through a hose. Make sure that the hose inner span is about double the size of the air pressure tube, otherwise the full pressure (difference from air inlet port to the end of the exhaust hose) is not transformed into mechanical energy. As mentioned in Chapter 2.4. pressure loss in pipes (whether supplying nor exhausting) must not exceed 0.5 bar in total.

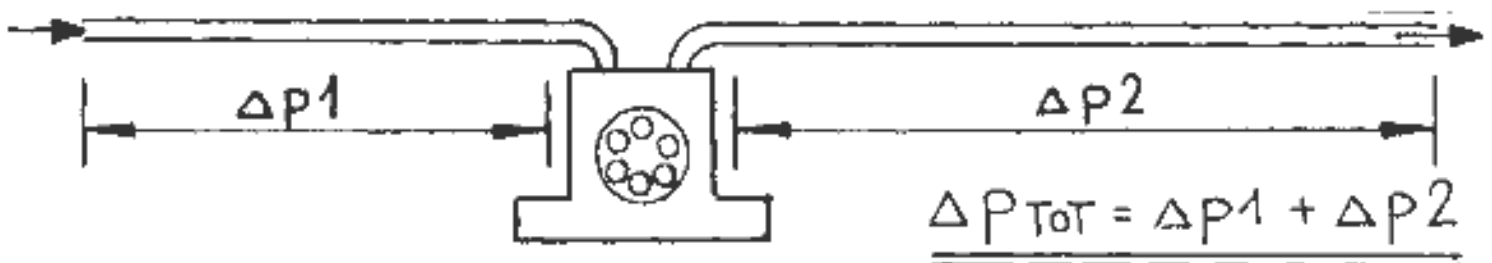

Pressure Loss

The exhaust pipe should not exceed 2 m.

6.1.4. Outdoor application

All FINDEVA vibrators may be used outdoors when operated under the following conditions :

The vibrator is to be installed so that no fluid may reach it. If the vibrator is exposed to fluids (rain drops or other moisture), one of the following steps must be taken:

- The vibrator should be mounted so that the exhaust port with silencer is turned against the ground or the exhaust port should be connected to a hose that is mounted so its end is against the ground, not allowing liquid or dirt to enter.

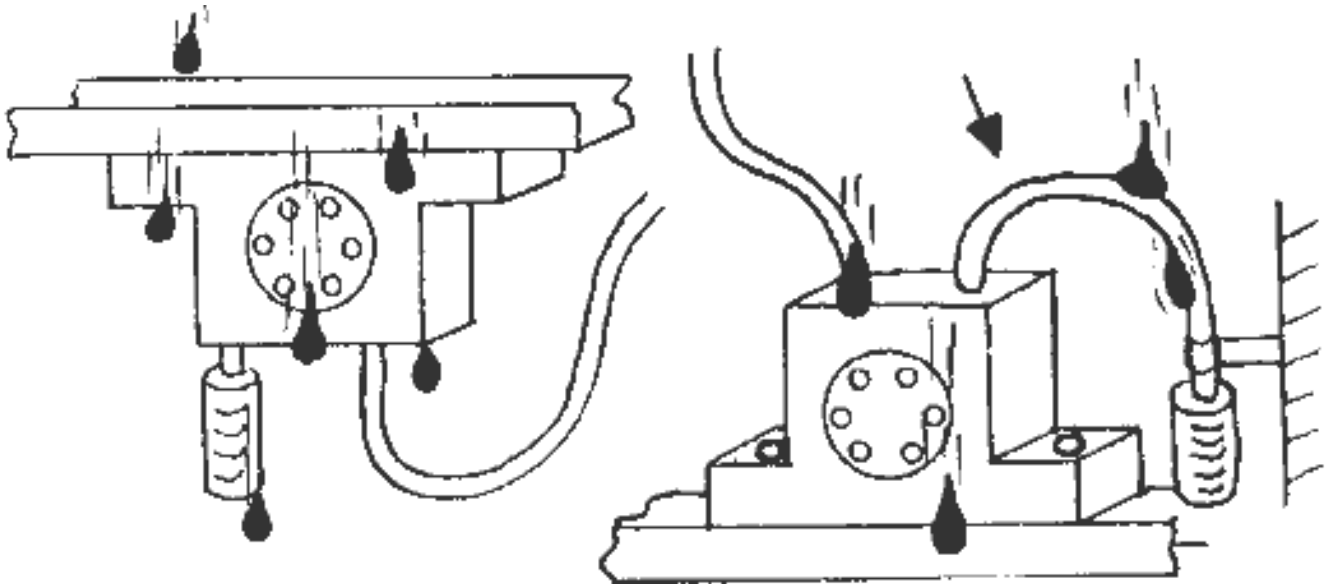

Mounting outdoors or exposed to liquids, dirt, etc.

- If the vibrator is exposed to fluids but above the measures can not be followed, use a silencer and have a continuous flow of about 0.5 to 1 bar (15 to 30 PSI) so that no fluids may enter.

CAUTION: Never operate vibrators without a silencer or exhaust hose if dirt, liquids or other particles (concrete powder, caustic solution, etc.) can enter the exhaust port.

6.2. Operation

After having successfully installed the vibrator, it can be set into operation.

WARNINGS:

- Wear ear protection around pneumatic vibrators!
- Operation without a silencer should be avoided to keep the noise level (and possibility of ear damage) reduced as much as possible!
- Make sure the lubricator (if any) is filled.
- Make sure that the maximum air pressure to the vibrator is 7 bar!
- Check again that mounting screws are tightly fastened.
- Make sure the air pressure tube is connected to the inlet port.
- Vibrators mounted on bins and hoppers should not be operated if bin or hopper is empty since this may cause structural damage.

When starting the first time, the vibrator might reach its nominal frequency and force after only a few minutes. This is because the moving parts are covered with grease and the temperature is low so that the grease is stiff. All vibrators are run during the final inspection in the plant for some minutes but because of stocking the grease may have a chance to clog again.

We recommend that you operate vibrators intermittently for several reasons:

- the lifetime of the vibrator is extended
- costly air pressure energy is conserved
- operate only when material flow is required and shutters and gates are open to prevent material from packing in the bin, hopper or chute.
- an Operating Factor of 10 to 30 seconds ON and 1 to 5 minutes OFF has been found to be most efficient for most applications.

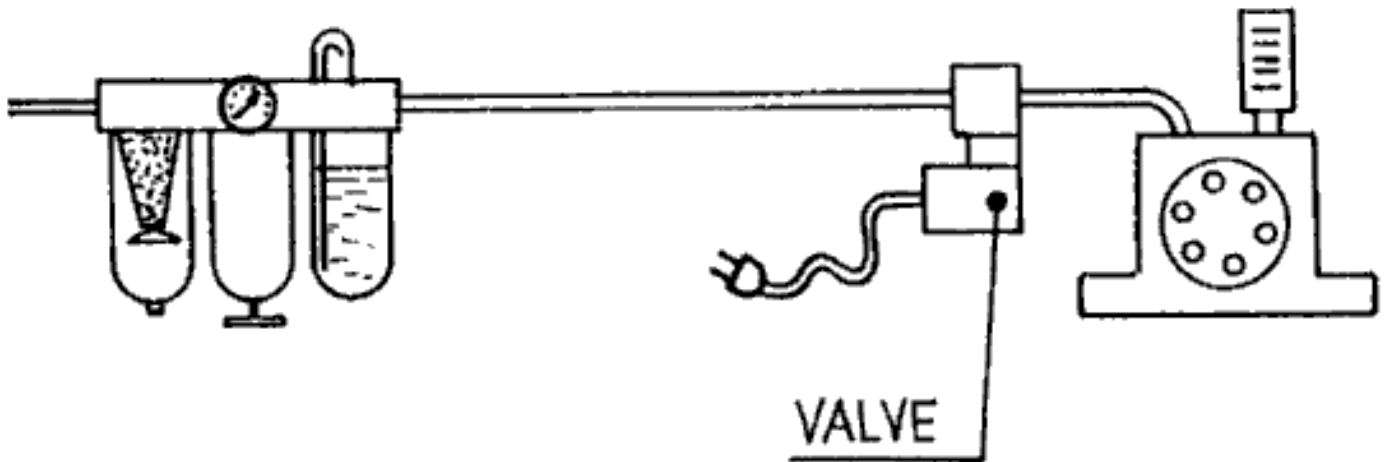

Intermittent operation

For intermittent operation, we recommend the use of electromechanical valves driven by timers or the machinery control system. The valve has to be set in line between the lubricator and the vibrator. The closer the valve is set to the vibrator the stronger start- and stop-intervals are. When the valve is set farther from the vibrator, the air pressure volume remaining in the air pressure tube has to be emptied and refilled.

Very often there is no need to run the vibrator at full power. Air power energy can be saved using a pressure regulator. Adjusting to the resonant frequency of the system extends the life time as well.

The frequency of all vibrators can be controlled with the help of pressure regulators in the supply pressure line. The FF-silencer connected to the piston vibrator's exhaust also allows adjustment of the vibration amplitude.

WARNING: For the following inspection wear ear protection !

When operating a vibrator for the first time, disconnect the exhaust hose and run the vibrator and measure its frequency and force. Do the same again with the exhaust hose mounted. Any difference in the values obtained show pressure and energy loss in the exhaust hose. If this occurs, increase diameter of the hose or cut the length of the hose.

The same procedure can be done with a silencer to verify the air flow is sufficient or to detect clogging.

If the vibrator cannot be set into operation or the desired operation power cannot be obtained please refer to Chapter 7.2.1. Fault Detection.

FINDEVA AG

Loostrasse 2 • CH-8461 Oerlingen • Switzerland

Tel. +41 52/319 25 61 • Fax +41 52/319 28 77 • E-Mail: info@findeva.com